

CHLORATES AND PERCHLORATES

Amazingly, chlorates and per chlorates can be produced through a simple electrochemical process from simple salts. Sodium Chloride (table salt) and Potassium chloride (another type of salt found on eBay) are the two most common. The salts are dissolved in boiling hot water until no more salt will dissolve. It is cooled and passed through a cloth filter to remove any un-dissolved salt. The remaining liquid is called a saturated solution. It is then placed in a container and a small DC current is passed through it with an anode and cathode.

The anode is the positive connection and the negative is referred to as the cathode. The entire body is called an electrolytic cell. There are many other chemical and thermal processes to produce chlorates and per chlorates but they are not well suited for small scale production. Another method I have used is to thermally decompose sodium hypochlorite (found in common bleach) into sodium chlorate by boiling down the bleach to a saturated solution and allowing cooling. Upon heating it will decompose into sodium chlorate and a small amount of sodium chloride. The sodium chlorate will form and crystallize and the sodium chloride that forms remains dissolved in the leftover water. Adding an aqueous solution of 100 grams potassium chloride per gallon of bleach used will change the sodium chlorate to potassium chlorate. Passing through a fine filter and then rinsing with ice cold water will remove excess salt.

Below is a picture of the resulting product prepared in a large pot outdoors on a camping stove burner.



CONSTRUCTING THE CELL

The components of an electrolytic cell are as follows.

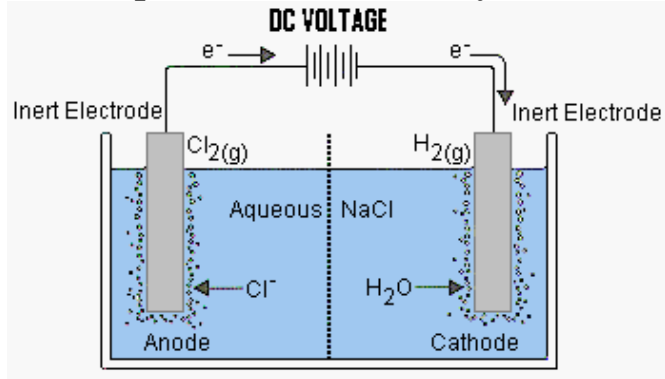

Cell body

Electrodes ----- Anode + Cathode -

Electrolyte (aqueous solution)

Power supply (DC voltage)

Additional components are also frequently seen such as a lid or cover, a vent pipe, a device for cooling or stirring the electrolyte, etc.

CELL BODY

The cell body material isn't as crucial as size. The size of the cell body or volume of electrolyte is relative to the size of your power supply used and size of anode and cathodes.

I like to be able to see what is going on inside during operation and like to use a transparent cell body. Some types of plastic will be attacked and become foggy, ultimately dissolving and contaminating your final product. I have had success using PVC pipe, acrylic containers, and glass. A stainless steel body can be used and the negative terminal of the power supply connected to it to act as the cathode. I recommend using a cell body similar to the one below which was purchased from Wal-Mart for \$4 dollars. It is made of acrylic and has a good sealing lid. It is easy to drill holes in it unlike glass and steel and when attaching the anode and cathode it will not conduct electricity causing a short. Further more, sealing compounds and glues adhere well to it. This particular



jar will hold 2 liters of fluid.

ELECTRODES

Anode material is critical in this type of cell.

Anodes are going to be your biggest expense in the production of a chlorate cell.

Suitable materials are Platinum, lead dioxide, or graphite.

You can buy any of these or make your own.

Graphite anodes are cheap and easy to find but I have not had much success with this. It will produce chlorate but is very slow to make per chlorate. Also it erodes over time and small particles will contaminate your electrolyte turning it a grey color. A filtering process can be done, but it is very laborious and wasteful. We will talk more about this later.

Below is a picture of a cell using a graphite rod as an anode and the cathode is copper wire. The electrolyte was a saturated potassium chloride solution. The anode and cathode sizes are huge and the DC voltage was 12 volts and 50 amps for 30 hrs to simulate corrosion and breakdown during a long runtime, maybe a month or so. A large amount of chlorine was produced and a small amount of potassium chlorate was harvested.



Lead Dioxide anodes are also very good, these can be bought but are very hard to find in this country, they are primarily made to produce chlorates and most plants are located over seas. Lead dioxide is a brown powder found in car battery cells. It is very conductive and almost perfect for the production of chlorates and per chlorates. It is usually permanently bonded by electroplating it onto a base material such as titanium. This is a very difficult thing to do. I

have had several dangerous and expensive failed attempts. I had to produce a lot of pure nitric acid and a few dangerous compounds to use as the electroplating solution. An alternative method has been developed and works quite well.

First a small motorcycle or car battery is cut open with a hack saw or dremel tool. I buy my motorcycle batteries from Wal-Mart for about \$15 with a \$7 core charge (I haven't tried to return my cores yet) , they are sold dry without the acid in them so I don't have to deal with cleaning out the cells with baking soda water.

The electrodes are removed and the dry brown powder is broken off into a dish. The all grey electrodes are discarded or recycled as they are just lead. I use a 2 part plastic epoxy from Wal-Mart and mix up a good sized glob. Then mix in your brown powder until a tacky dough is achieved. I then place a lot of finely powdered lead dioxide onto a sheet of wax paper, roll my dough into a rod shape about 3/8 of an inch thick or so and then roll and coat it intimately in the fine powder. This takes some practice to get perfect and tightly compacted so it will not fall apart. There may be other ways of creating a good anode and I encourage experimentation. I have heard of one being made from a piece of PVC pipe soaked in MEK until the outer surface was slightly melted and then it was rolled in the fine lead dioxide powder and let dry.

If either of these two methods are used when the cell is first run a lot of the powder will fall off when the reaction takes place. I recommend running it for 20 minutes and then changing out the solution. The rolled log anode works but has a lot of resistance since it is not a solid piece so a lot of energy is wasted.

Below is a photo of a motorcycle battery cut open so you can get an idea of what is involved. The electrode frame that holds the powder is made of lead and is not suitable for use in a chlorate cell.



Platinum anodes are the absolute best; they work very efficiently and produce a high yield of chlorate or per chlorate. They will last a lifetime if they are not abused or neglected. They are also very expensive. The first one I purchased was 1/8 thick and 3 inches long and costs about \$175. They can be bought from several sources but I have found they are only affordable if bought from China or India and bought in bulk.

We currently have a large shipment of 1/4 x 6 inch coming and will be listing our excess on eBay for a very good price.

An alternative would be to buy some thick platinum wire from a jeweler; any jeweler can order it for you. Or buy it on eBay... I have seen it listed on eBay several times. It can be coiled around a pen to give it a spring shape allowing more surface contact with your electrolyte.

In theory any platinum will work, scrap jewelry from eBay is a good way to go. We bought a pure platinum necklace for a very good deal and it seems to make a great anode. It is not quite as efficient as a solid piece of wire or an actual platinum anode designed for this use.

I highly recommend spending the money on a platinum anode of some sort. It will last forever, no work is required to prepare it for use and it eliminates the task of filtering and waste as with graphite.

Below are some pictures of platinum anodes. Rod anodes seem to work best.



Cathodes can be made of stainless steel, titanium, copper, or brass. Stainless works best in my opinion, I have not tried titanium as of yet, and copper and brass will corrode and contaminate your solution over time... This isn't really a big problem and contaminants can be filtered out as you will read in the filtering stage. A length of thin copper tubing matching the size of your

rod anode works well and is very economical. I use copper coated carbon rods found at welding shops, these are easy and available in a wide variety of sizes. I bought these two packs for about 4 dollars on eBay just to prove that I can.



The ends are dipped in epoxy so that no carbon comes in contact with the electrolyte, causing contamination.

Preparing electrolyte:

Preparing a saturated solution of electrolyte is very simple. I usually prepare about 1 gallon at a time and store in sealed containers.

I start with 400 grams of potassium chloride or 600 grams sodium chloride per liter of water.

Mix and bring to a boil while stirring. Continue until no more will dissolve.

Allow to cool to room temp and then pour through a filter or piece of cloth to strain out un-dissolved salt.

You now have an electrolyte.

Starting with potassium chloride or sodium chloride solution will result in the corresponding chlorate being produced.

In the preparing per chlorates section we will discuss the advantages and disadvantages of each.

DC Power supply:

Many different sources can be used as a power supply.

We have set up cells using scavenged computer power supplies, power supplies from microwaves, car battery chargers and professional variable DC power supplies. The optimum voltage for Chlorate production is between 3-5 volts

and 2-3 amps, the optimum for per chlorate production is about 6-7 volts and 3 amps.

A computer power supply can be bought new for \$10 dollars on eBay and puts out 5 volts dc. A battery charger with a 6 volt 2 amp setting works ok. We have found that our local goodwill has stacks and stacks of dead microwaves for \$1! Most of these are not functioning because the contacts on the door switch have corroded or failed. This seems to be the best route if you have some experience with electronics as the power supply will need to be tweaked a little.

If you have a local ham radio or electronics shop in town, give them a call I'm betting they would love to help you out.

I have bought several lab variable voltage power supplies on eBay. Prices range from \$20 dollars to \$200. It should be capable of outputting at least 15 volts and 2 or 3 amps constant.

There are also nicer ones with double output leads to operate 2 cells at once. These two are listed on eBay as this is being written. The analog one is \$30 dollars and the digital unit is \$62.

You can increase or decrease resistance of a cell by moving the anodes and cathodes closer or farther apart. Moving them closer together will decrease resistance but cause more heat, and current flow. Moving them apart will cause more resistance, and reduced current. Some testing may have to be done to see what your chosen power supply will handle.



Operating your cell:

Once you have your completed cell set up in a place to run, fill it with electrolyte and provide current to the anode and cathode. Small amounts of dissolved chlorate will form in your solution within 1 hr. Run times vary greatly with each cell design. It is not possible to give an exact time. I usually run my cells for 3-4 days with fresh electrolyte.

When being run with potassium chloride solution, Potassium chlorate will start to form and crystallize and will settle on the bottom.

Potassium chlorate is relatively insoluble in water unless it is very hot but some will be dissolved and invisible in your solution. You can cool your cell in the freezer (if it will fit) and pour this solution through a filter to harvest what chlorate has formed. Your first run will have a pretty small amount and you may be disappointed at first. Take your still saturated solution and boil it until half of the water is gone. Once it has cooled again return it to your cell and top off with more potassium chloride solution. Now when you run your cell for the second time you will already have a high concentration of dissolved chlorate in it. Potassium chlorate will crystallize and precipitate and settle to the bottom at a much faster rate. You can harvest the potassium chlorate daily or every two days and the steps can be repeated or you can skip the boiling down step and keep topping off with salt solution. Since Potassium chlorate isn't very soluble filtering impurities can be a pain. If your cell design is good and you are using platinum anodes you may be able to skip filtering. If you have to filter you will have to dissolve your crystals in 1 liter of boiling water to every 350 grams, add more water slowly until you have used just enough to completely dissolve it. Pass through a filter and boil the water back down, cool to near freezing and filter out your crystals again.

Potassium chlorate can then be converted to potassium per chlorate via thermal decomposition. Since chlorates are thermodynamically unstable over time they will decompose into a mixture of chlorides and per chlorates. This auto oxidation process is slow at room temperature. When chlorates are heated the reaction is sped up dramatically. This step is always done outdoors.

The potassium chlorate crystals are placed in a glass Pyrex baking dish. I place this in a cheap toaster oven from Wal-Mart on high setting. Once the crystals start to melt, I slowly back down the heat until they stop melting. Then in very small increments I increase the heat just to the point where it melts again and hold this temperature. It is let run for about 2-3 hrs depending on how much chlorate is used. Once the auto oxidation process starts potassium chloride and potassium per chlorate will form. Both of these melt at a higher temperature than chlorate. The melted mixture will start to get hard again because the oven is set to not go higher than what chlorate melts at. Cool this to room

temperature, dissolve in water and re-crystallize as described earlier to dissolve and remove what potassium chloride has formed.

This is the method I use most often, I prefer to convert potassium chloride to potassium chlorate and then to potassium perchlorate by thermal decomposition. It seems much faster to me.

If sodium chloride is used as your starting solution it is converted to sodium chlorate the same way that potassium chlorate is formed. The main difference is that you will not see sodium chlorate precipitating out of the solution and settling to the bottom. Sodium chlorate is very soluble in water and will remain dissolved in the solution. After an initial run time with fresh electrolyte (3-4 days) you can choose to precipitate out potassium or barium chlorate by way of a metathesis reaction. For every 100 grams of sodium chloride that you started with in your electrolyte, weigh out 125 grams of potassium chloride or 355 grams of barium chloride. Prepare a saturated solution by dissolving it in boiling hot water just as you would when preparing electrolyte.

If you're using a 2 liter cell body you will have started with roughly 1200 grams of sodium chloride in your solution. So you'll need to dissolve 1500 grams of potassium chloride if you want to precipitate potassium chlorate. When the solution has cooled to room temperature add this to the electrolyte. The solution will turn cloudy white as the potassium chloride and sodium chlorate react and potassium chlorate will fall to the bottom. Now boil this solution adding small amounts of water until all chlorate has dissolved. Continue boiling until you see a foamy crust forming on the edges of the pot where the water line is and on top of the solution. At this point the solution is fully saturated. Add a small amount of water to dissolve the crust back into the solution. Cool this solution in the freezer to 0 degrees and very pure chlorate crystals will form.

If you want to make perchlorates you will start with sodium chloride solution. Run this in your cell for 3-4 days, take a small amount out and react with potassium chloride solution to verify that there is a high concentration of chlorate formed.

When you have a high concentration of sodium chlorate formed in your cell, you simply let the cell run longer at a higher current, once all the chloride has been converted to chlorate perchlorates will start to form. I switch my power supply to 7 volts 3 amps. And let run for 2 days. Theoretically you can increase current as much as you want to increase the rate of production with perchlorates. But with increased current you will have increased heat and

increased erosion rate of your electrodes. I recommend just staying at 7 volts or so.

****** Important******

Once you have let your cell run to form sodium perchlorate, you can decide if you want potassium perchlorate, or ammonia perchlorate.

Before you start the double decomposition process to form ammonia perchlorate or potassium perchlorate from sodium perchlorate all residual chlorate must be destroyed.

Even if you let your perchlorate cell run for twice the amount of required time. Trace amounts of chlorate will remain in the solution. Chlorate is incompatible with pyrotechnic compositions containing sulfur. If you plan to label your product as perchlorate, for safety reasons all chlorate must be removed even if you do not plan on using it in sulfur containing compositions. Simply add about 3-4 cap full's of muriatic acid per liter of solution. Making your solution slightly acidic and then boiling for 15 minutes will thermally and chemically destroy all the chlorate. A tablespoon of sodium hydroxide or lye will bring your solution back to alkali or neutral. \

Both muriatic acid and sodium hydroxide (lye) can be bought from Wal-Mart or Lowes. The Lye is sold as a white powdered or granular drain cleaner. Some drain cleaners are sulfuric acid based, you should read the label if you are unsure. The two brands that I use are pictured below.



Now dissolve 70 grams of potassium chloride or 50 grams of ammonium chloride for every 100 grams of sodium chloride in your starting solution and dissolve in as little water as possible. Add this to your electrolyte.

A white precipitant of the corresponding perchlorate crystals will form and settle to the bottom.

Bring this solution to a boil adding small amounts of water until all crystals have re-dissolved. Adding a teaspoon of sodium hydroxide per liter at this step will ensure that your perchlorate will not be acid. Traces of acids can be dangerous and they will attack pyrotechnic compositions causing them to become unstable and possibly spontaneous combustion.

Allow your solution to cool, I cool in the freezer but it is not necessary. Once at room temperature you can filter out your perchlorate crystals.

Perchlorate can be dried on a glass baking dish in your oven at the lowest setting. It is now ready for use.

Once you have performed these steps a few times chlorate and perchlorate can be harvested, filtered, washed, and dried in an hour or two depending on batch size.

Cell designs can vary greatly. We have several cells operating with graphite anodes and recycled pickle jars, and small battery chargers as power supplies. These were put together for less than \$25 dollars.

Our best performing cell uses a \$50 dollar platinum rod anode (1/4x6) from eBay. A stainless steel rod was used as a cathode and was found as free scrap. A \$4 dollar acrylic jar (2 liters) from Wal-Mart. A \$30 variable dc power supply from eBay. And about \$15 dollars worth of electrical wire and epoxy from the automotive section at Wal-Mart.

Total cost was about \$100 dollars and has paid for its self ten times over.

I have seen potassium perchlorate sell on eBay for as much as \$40 dollars a lb!

Sodium chloride (table salt) is cheap and found at grocery stores.

Potassium chloride is harder to find it can be found online or ordered from chemical warehouses. It usually costs around \$1.50 a lb. I buy mine in bulk and have some available on eBay.

I have a hard time finding ammonium chloride but have seen it pop up on eBay from time to time. I have heard that it be found at electronic stores for cleaning soldering irons.

Once setup, starting with sodium chloride solution, potassium perchlorate can be produced for under \$1 a lb.

Our best performing 2 liter cell produces about 600 grams of potassium chlorate per day. We choose to thermally decompose our chlorate into perchlorate which wastes some chlorate. Our harvest of perchlorate is usually around 450 grams or about a lb.

Here are some pictures of how a simple cell is constructed.



The 1/4 x 6 inch anodes and cathodes are shown. We have attached a splicer to the top of the anode to act as a clamp or wire lead.



Two holes are drilled through the lid and rubber grommets are inserted. The lid is easily removed from the hinge mechanism with some pliers.



Here is a completed cell with a platinum anode and stainless steel cathode. The battery charger is set to the 6 volt setting and the electrolyte is a saturated potassium chloride solution. Instead of using the battery charger the wire leads will be attached to a variable DC power supply. A very small amount of Potassium chlorate has settled to the bottom.